



DOCUMENT TITLE	Invitation to Tender –Technical specifications	DOCUMENT REFERENCE	ITT
AUTHOR	Peter Wright	DATE	18/03/10
ISSUE	1	DOCUMENT TYPE	Invitation to Tender

Quotation requirement

Provision of MAG's requirement for Protection Equipment

Procurement Volume through previous years

Indicative estimates of procurement volume of items purchased during the past two years

	2008	2009
	Quantity	Quantity
<i>Fragmentation vest</i>	38	55
<i>Demining Helmet with visor</i>	350	54
<i>Polycarbonate Visor</i>	66	235

MAG offers no guarantees that the level of purchase for the period cover by this invitation to tender will meet or exceed the indicative figures supplied above.

Technical Specifications

Fragmentation vest

The vest should be designed to offer protection to a large area of the body while maintaining mobility; it should also be light and comfortable.

The fragmentation vest should provide full protection to the front of the body from the neck to the waist with a second apron extending from the waist to cover the groin and front of the thighs to the ground when the wearer is in a kneeling position.

Protection must also be afforded to the sides and shoulders, a second collar functioning as a mechanical link between the visor and the apron must also be fitted to prevent blast from entering under the visor.

The outer layer must be of a robust material that is easy to clean and all attachments should be strong enough to allow for the wearer to be lifted or dragged in the event of an injury.

Features required:

- Protection level: STANAG 2920 minimum / 17 grain FSP V50 = 450m/s
- Color: Blue with MAG logo at the front
- Material: kevlar or aramid
- Adjustable at the sides
- Belly band
- Large detachable groin protector
- Throat protector
- Front and back pocket for ballistic plates
- Fully adjustable at waist and shoulders.
- Body belt.
- Evacuation handle on the front
- Outer fabric with high abrasion resistance, washable at 30°C
- Protective bag



DOCUMENT TITLE	Invitation to Tender –Technical specifications	DOCUMENT REFERENCE	ITT
AUTHOR	Peter Wright	DATE	18/03/10
ISSUE	1	DOCUMENT TYPE	Invitation to Tender

The following specifications for the fragmentation vest are given as a guide only.
Back of the vest:

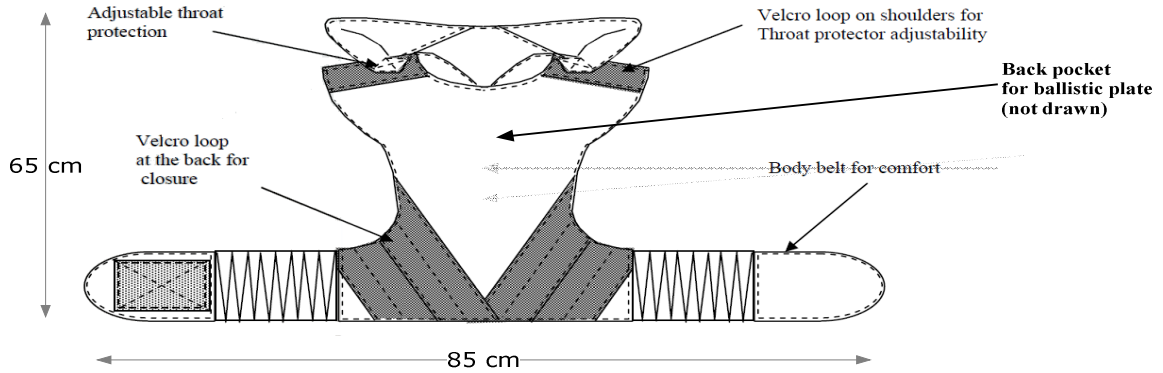

Front of the vest:

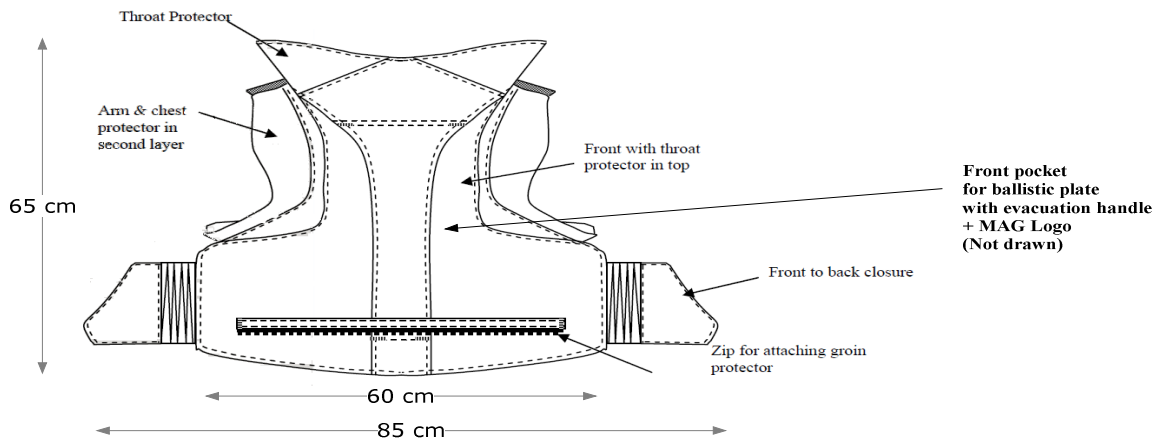

Groin protector:

DOCUMENT TITLE	Invitation to Tender –Technical specifications	DOCUMENT REFERENCE	ITT
AUTHOR	Peter Wright	DATE	18/03/10
ISSUE	1	DOCUMENT TYPE	Invitation to Tender

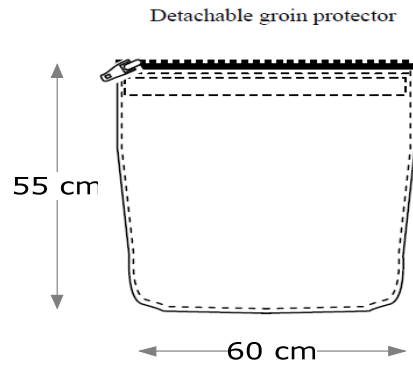

Polycarbonate visor

The visor should cover the entire face, including sides, forehead and neck.
The headband must be detachable and be surrounded by a washable material
The strap should fasten with Velcro.

Features required:

- 5mm thickness polycarbonate
- Protection level : STANAG V50 : 250m/s or more
- Dimensions : Height 30 cm approx , diameter 23cm approx
- Protective bag

Demining helmet with visor

The visor should be detachable and should be adjustable to different positions.

Features required:

- Protection level: STANAG 2920 V-50 (250 m/sec),
- Dimensions : Height 12 cm approx
- Protective bag